

1 CORNICE DETAIL  
1 3/4" = 1'-0"

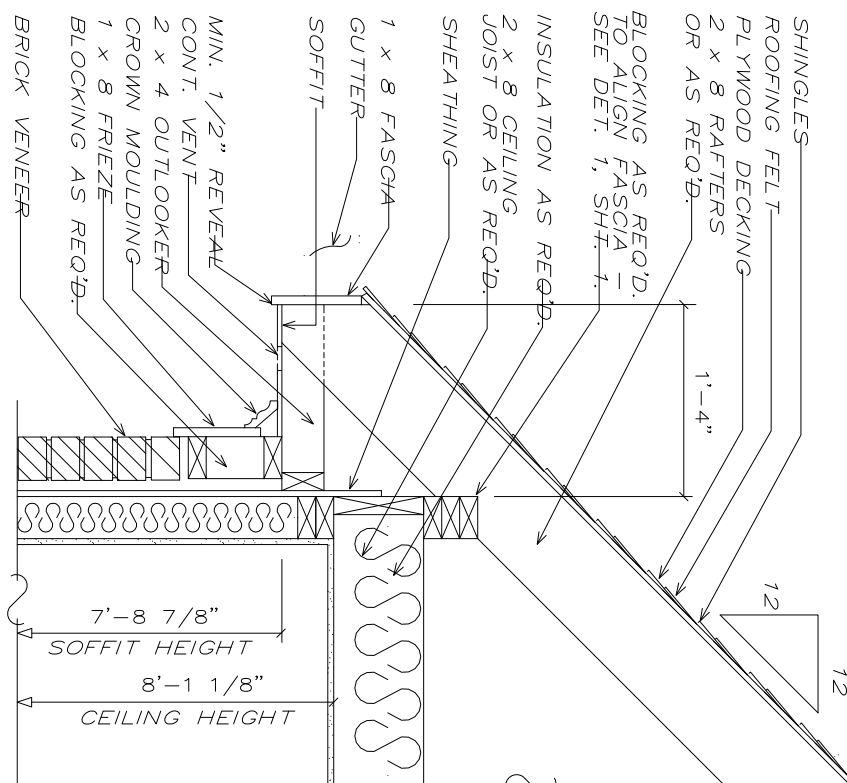

2 CORNICE DETAIL  
1 3/4" = 1'-0"

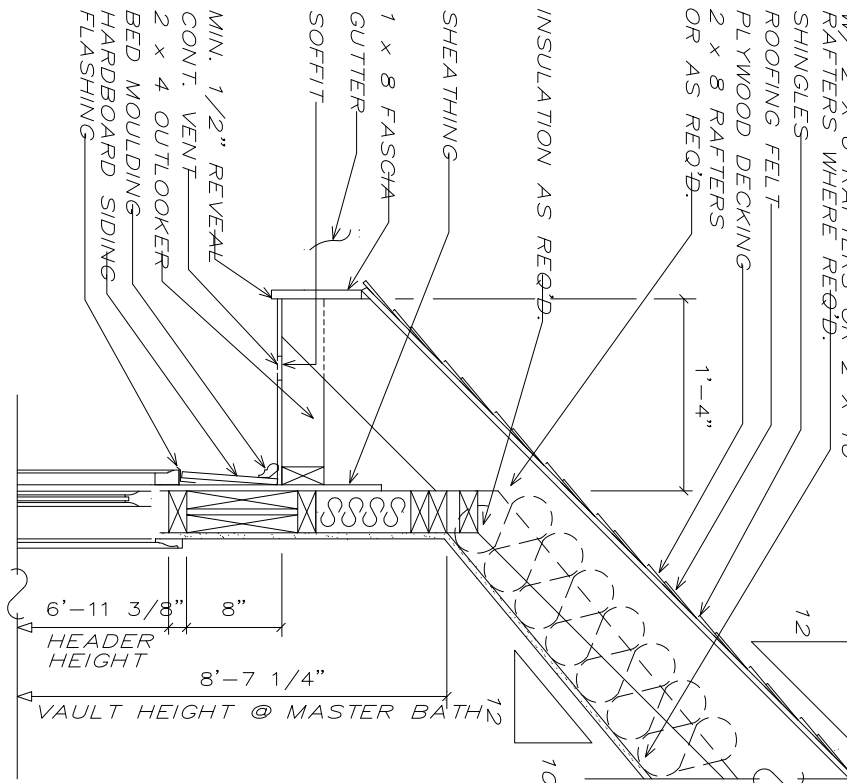

3 CORNICE DETAIL  
1 3/4" = 1'-0"

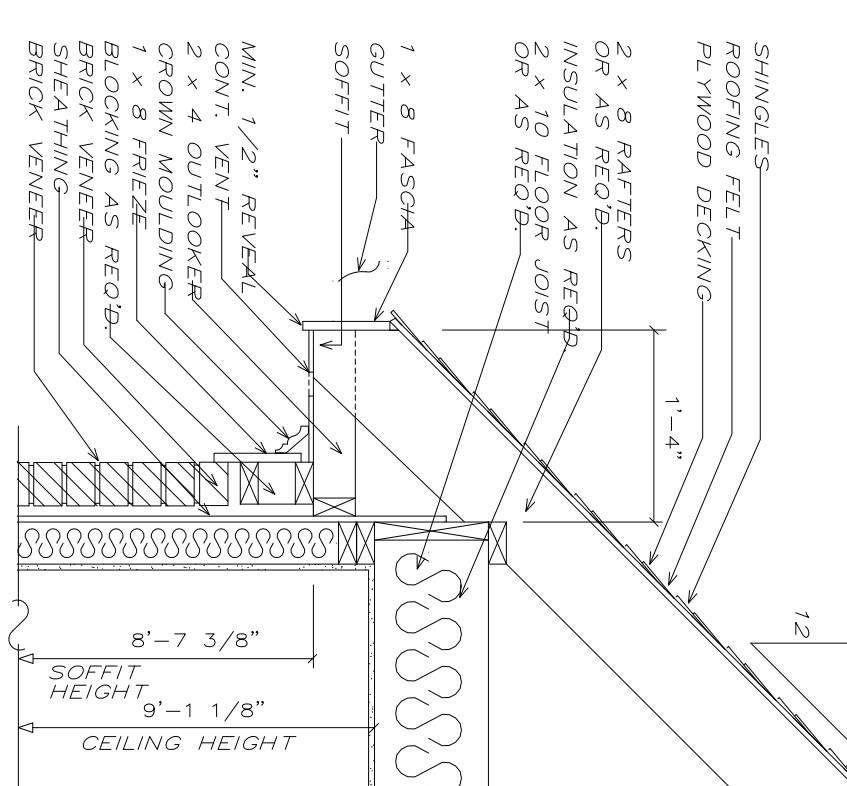

4 CORNICE DETAIL  
1 3/4" = 1'-0"

NOTE: RAFTERS ARE PITCHED FROM TOP OF CEILING JOISTS SEE DETAILS

NOTE: ATTIC VENTILATION PER LOCAL CODES AND REQUIREMENTS

NOTE: WHEN TWO ROOFS INTERSECT WITH DIFFERENT ROOF PITCHES, BLOCK TOP OF STUD WALLS AS REQ'D. TO LINE UP FASCIAS AT A MINIMUM OF 1'-0" OVERHANG

NOTE: RAFTERS ARE PITCHED FROM TOP OF A 2'-0" KNEEWALL AT GARAGE. SEE DETAILS

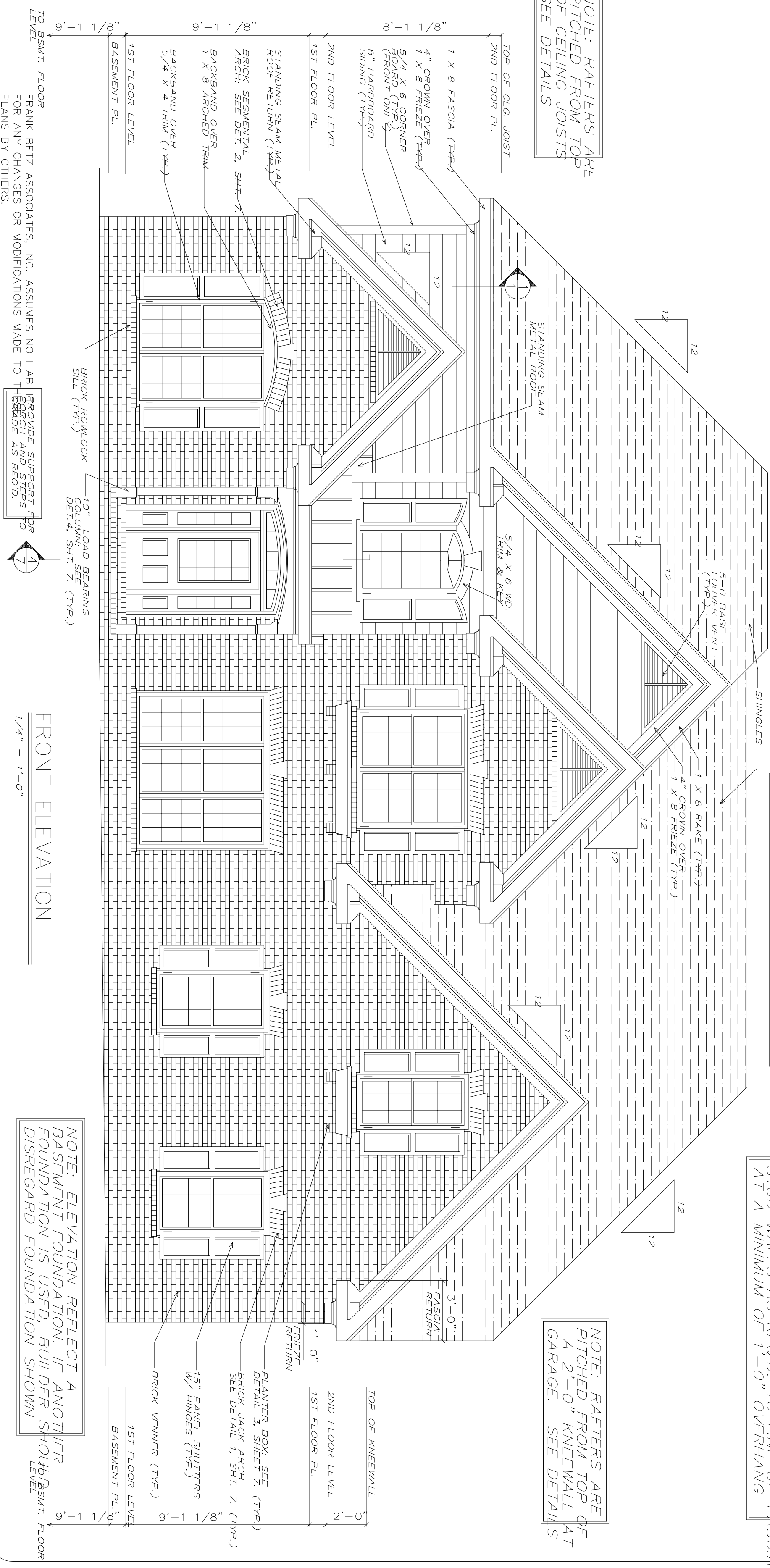

FRONT ELEVATION  
1/4" = 1'-0"

NOTE: ELEVATION REFLECT A BASEMENT FOUNDATION. IF ANOTHER FOUNDATION IS USED, BUILDER SHOULD DISREGARD FOUNDATION SHOWN

TO BSMT. FLOOR  
FRANK BETZ ASSOCIATES, INC. ASSUMES NO LIABILITY FOR ANY CHANGES OR MODIFICATIONS MADE TO THIS PLAN BY OTHERS.

PROVIDE SUPPORT FOR BRICK ROWLOCK SILL (TYP.)  
10" LOAD BEARING COLUMN DET. 4, SHIT. 7 (TYP.)

TOP OF KNEEWALL  
2ND FLOOR LEVEL  
1ST FLOOR LEVEL  
BASEMENT PL.  
1ST FLOOR LEVEL  
BASEMENT PL.  
15" PANEL SHUTTERS W/ HINGES (TYP.)  
BRICK VENER (TYP.)  
PLANTER BOX: SEE DETAIL 3, SHEET 7 (TYP.)  
BRICK JACK ARCH SEE DETAIL 1, SHIT. 7 (TYP.)  
FRIEZE RETURN  
3'-0" FASCIA RETURN