

FRANK BETZ ASSOCIATES, INC. ASSUMES NO LIABILITY FOR ANY CHANGES OR MODIFICATIONS MADE TO THESE PLANS BY OTHERS.

COPYRIGHT © 2000 BY FRANK BETZ ASSOCIATES, INC. NOT TO BE REPRODUCED

FRONT ELEVATION

TO BSMT. FLR. LEVEL

1 CORNICE DETAIL

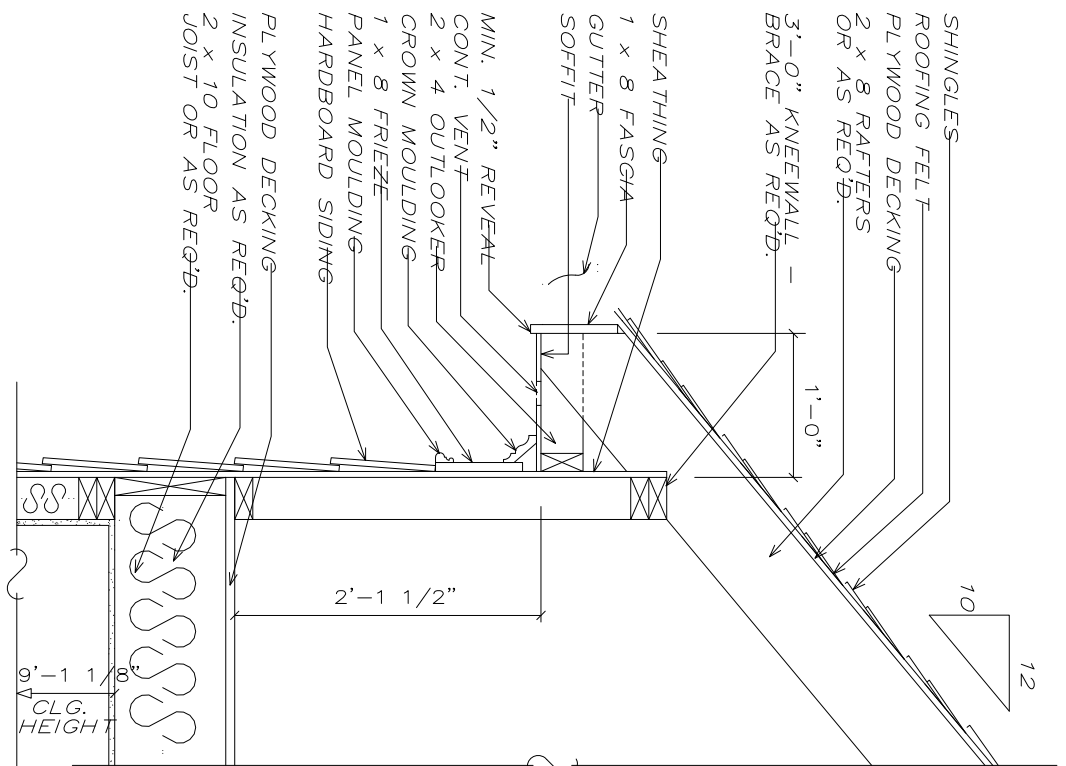

2 TYP. PEDIMENT DETAIL

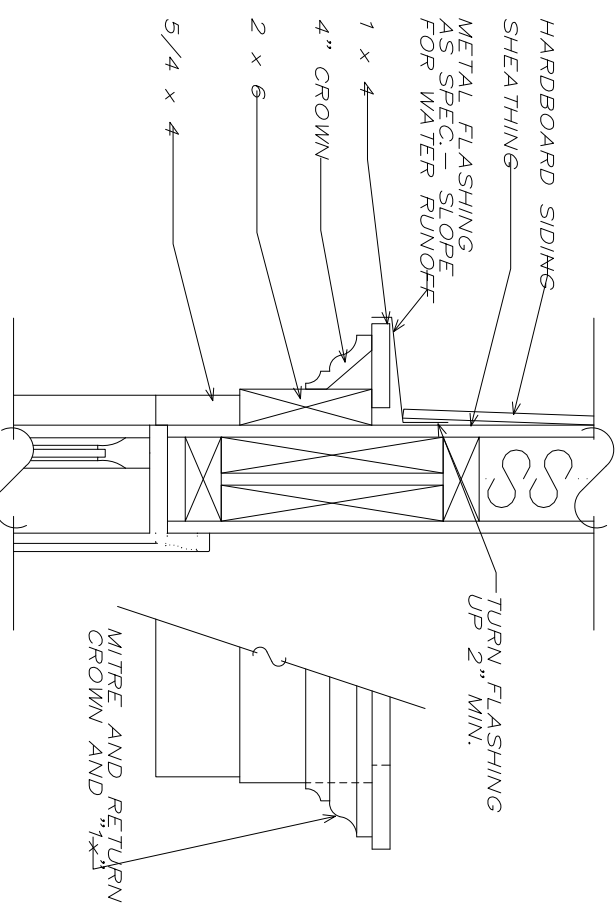

3 TYP. PLANTER DETAIL

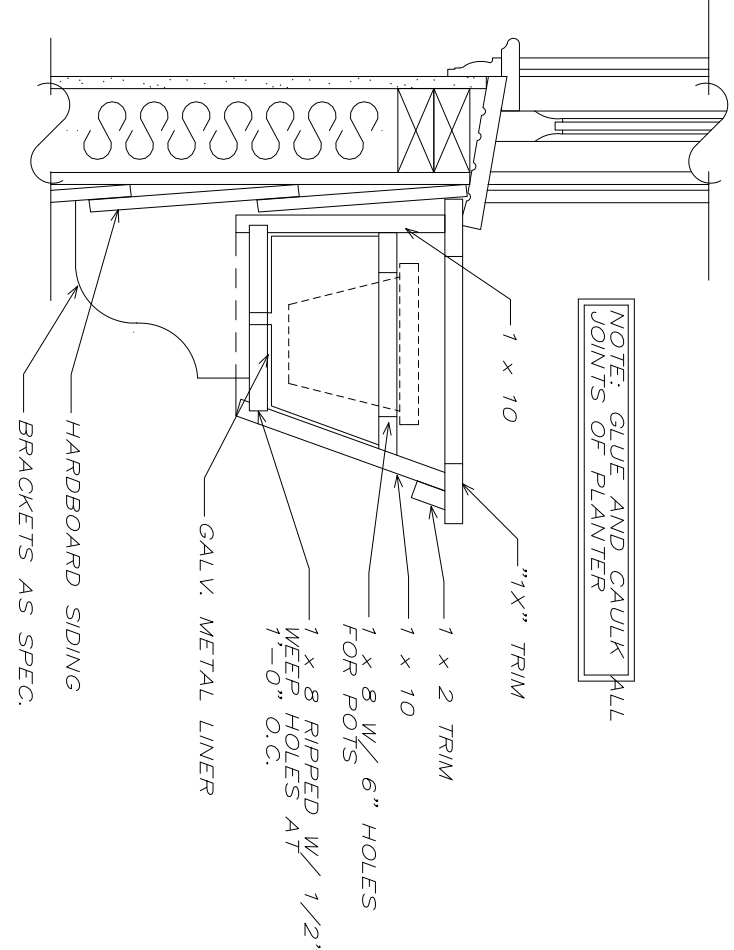

4 WATERTABLE DETAIL

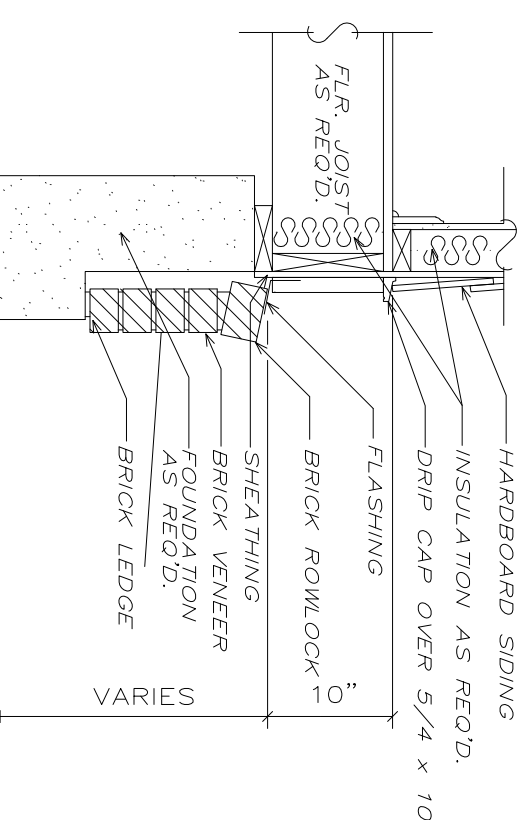

NOTE: ATTIC VENTILATION PER LOCAL CODES AND REQUIREMENTS

NOTE: WHEN TWO ROOFS INTERSECT WITH DIFFERENT ROOF PITCHES, BLOCK TOP OF STUD WALLS AS REQ'D. TO LINE UP FASCIAS AT A MINIMUM OF 1'-0\"/>

NOTE: RAFTERS ARE PITCHED FROM TOP OF KNEEWALLS SEE DETAILS

FBA

FRANK BETZ ASSOCIATES, INC.
2401 LAKE PARK DRIVE/SUITE 250
SMYRNA, GEORGIA 30080
770/431-0888
www.frankbetz.com

ELEVATIONS / DETAILS
THE KEARNEY

HOMEPLANS
DESIGNED FOR TODAY'S MARKET

DATE	REV	DATE	REV

Copyright Frank Betz Associates, Inc. All Rights Reserved. The Duplication, Reproduction, Copying, Sale, Rental, Licensing, or any other distribution or use of these drawings, any portion thereof, or the plans depicted hereon is Strictly Prohibited unless expressly authorized in writing by FBA, Inc.

SHEET

DATE 11/27/00

BY PLD & MWB

OF 7